

MCAS New River Water Distribution System - PWSID: NC0467042
Voluntary Monitoring Detected Contaminants

Contaminants	Average Amount Detected	Unit of Measure	Range	
			Low	High
Finished Drinking Water Detections				
Explosive Constituents				
1,3,5-Trinitrobenzene	0.15	ug/L	Only detection	
1,3-Dinitrobenzene	0.70	ug/L	0.45	0.98
Perchlorate	0.38	ug/L	0.04	0.79
Inorganic Contaminants				
Arsenic	0.39	ug/L	Only detection	
Barium	0.62	ug/L	0.37	0.75
Calcium	53,000	ug/L	20,000	70,000
Chloride	23	mg/L	15	39
Iron	20	ug/L	Only detection	
Magnesium	3,433	ug/L	1,300	4,500
Nickel	1.05	ug/L	0.99	1.1
Potassium	9,733	ug/L	6,200	12,000
Sodium	39,300	ug/L	1,900	97,000
Strontium	171	ug/L	64	230
Volatile Organic Contaminants				
Bromodichloromethane	9.27	ug/L	8.40	11
Bromoform	0.45	ug/L	Only detection	
Chloroform	22	ug/L	16	25
Dibromochloromethane	3.47	ug/L	2.2	6
Raw Groundwater Water Detections				
Explosive Constituents				
Perchlorate	0.22	ug/L	0.05	0.38
Inorganic Contaminants				
Arsenic	0.41	ug/L	Only detection	
Barium	1.76	ug/L	0.46	5.1
Calcium	74,214	ug/L	62,000	88000
Chloride	18.87	mg/L	8.4	77
Cobalt	0.19	ug/L	0.13	0.24
Copper	0.17	mg/L	0.06	0.26
Iron	108	ug/L	19	350
Lead	0.27	ug/L	0.21	0.32
Magnesium	4,858	ug/L	4,000	6,000
Manganese	2.4	ug/L	1	5.9
Nickel	3.35	ug/L	0.52	30
Potassium	9,885	ug/L	6,300	13,000
Selenium	1.5	ug/L	Only detection	
Sodium	20,664	ug/L	1,300	48,000
Strontium	254	ug/L	210	350
Zinc	30	ug/L	16	38
Synthetic Organic Contaminants				
Di(2-ethylhexyl)adipate	0.68	ug/L	0.66	0.69
Microbiological Contaminants				
Total Organic Carbon	2.69	mg/L	1.5	4.5

NOTE – This database contains information about MCB Camp Lejeune's drinking water systems and raw water supply. It was Developed only to assist the Base manage and maintain analytical data concerning chemicals detected in drinking water. While EMD has made every effort to ensure the completeness and accuracy of the database, some errors and omissions may remain. Therefore, the user should always refer to the original report to ensure maximum accuracy and completeness.

MCAS New River Water Treatment Process

Groundwater is pumped from the drinking water supply wells to a water reservoir located at the MCAS New River Water Treatment Plant. Water is pumped to the top of the reservoir and cascades down providing aeration. This water is then pumped to a series of cation and anion exchangers (softeners) to remove particles. Chlorine, caustic and zinc orthophosphate are added to the water before it enters the finished water reservoir. When water is needed by customers, it is pumped from the reservoir and distributed throughout the MCAS New River Community water system.

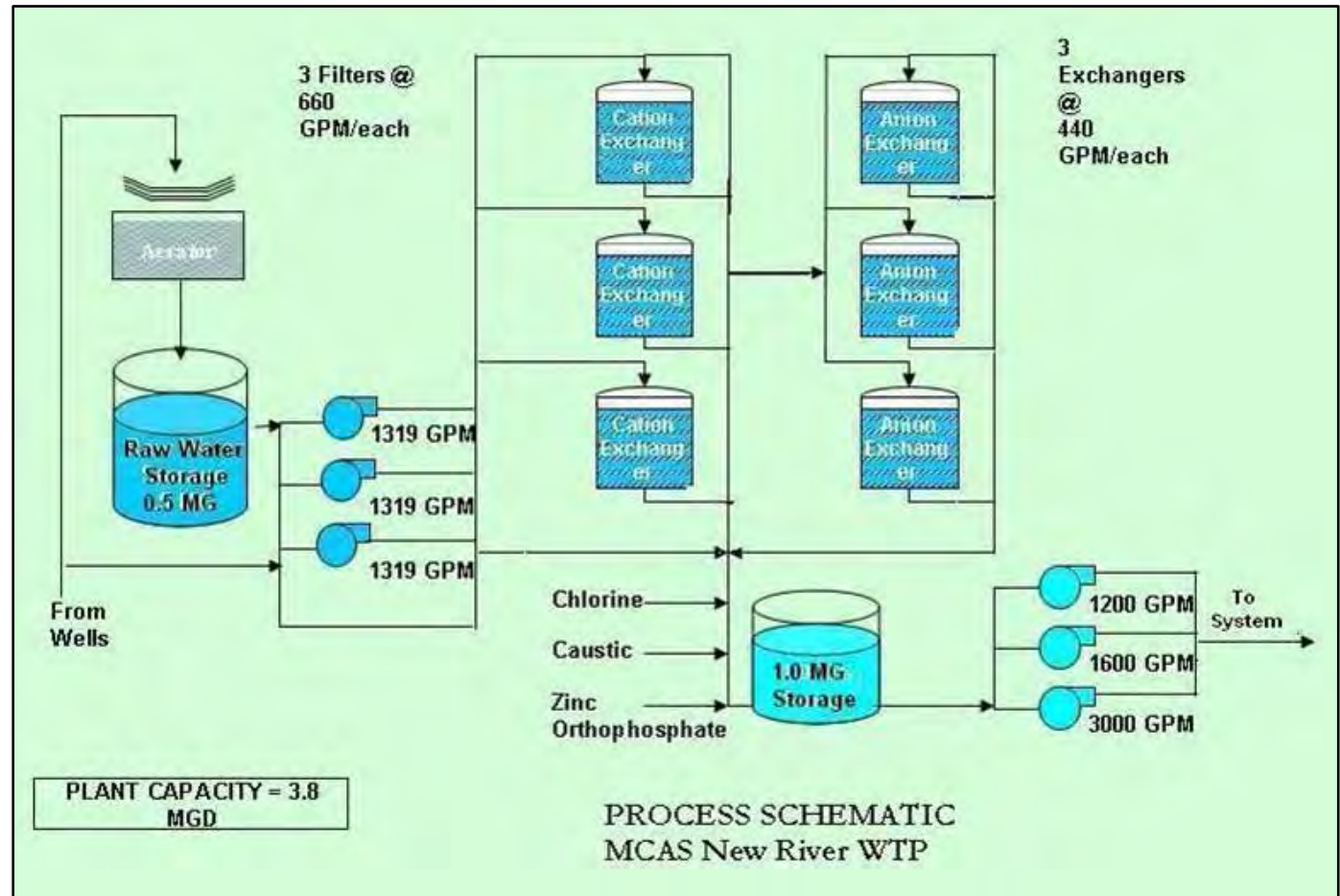



SOURCE WATER ASSESSMENT PROGRAM (SWAP) RESULTS

The North Carolina Department of Environmental Quality (NCDEQ), Public Water Supply Section (PWSS), Source Water Assessment Program (SWAP) conducted assessments for all drinking water sources across North Carolina. The purpose of the assessments was to determine the susceptibility of each drinking water source (well or surface water intake) to Potential Contaminant Sources (PCSs). The results of the assessment are available in SWAP reports that include maps, background information, and a relative susceptibility rating of Higher, Moderate or Lower. The relative susceptibility rating of each source for the MCAS New River Water Treatment System was determined by combining the contaminant rating (number and location of PCSs within the assessment area) and inherent vulnerability rating (i.e., characteristics or existing conditions of the well or watershed and its delineated assessment area). The assessment findings based on the SWAP report completed on July 11, 2015 are summarized in the table below:

MCAS New River Drinking Water Supply Wells	
Source Name	Susceptibility Rating
VL 101	Moderate
VL 102	Moderate
VL 103	Moderate
VL 104	Moderate
VL 105	Moderate
VL 106	Moderate
VL 107	Moderate
VL 109	Moderate

It is important to understand that a susceptibility rating of “higher” does not imply poor water quality, only the system’s potential to become contaminated by PCSs in the assessment area.

The complete SWAP report for the MCAS New River Water Treatment System may be viewed on the web at <http://www.ncwater.org/?page=600>. In order to access this report you will need to enter either the system name or PWS ID. Both have been provided below. Please note that because SWAP results and reports are periodically updated by the PWS Section, the results available on this website may differ from the results that were available at the time this report was prepared.

System Name: USMC—New River Air St

PWS ID: 0467042



WATER CONSERVATION

Did you know that the average U.S. household uses approximately 400 gallons of water per day or 100 gallons per person per day? You can play a role in conserving water by becoming conscious of the amount of water your household is using and by looking for ways to use less whenever possible. It is not hard to conserve water. Small changes can make a big difference. Here are a few tips:

- Take short showers – a 5 minute shower uses 4 to 5 gallons of water compared to up to 50 gallons for a bath.
- Run your clothes washer and dishwasher only when they are full. You can save up to 1,000 gallons a month.
- Shut off water while brushing your teeth, washing your hair and shaving and save up to 500 gallons a month.
- Check every faucet in your home for leaks. Just a slow drip can waste 15-20 gallons a day.
- Check your toilets for leaks by putting a few drops of food coloring in the tank. Watch for a few minutes to see if the color shows up in the bowl. It is not uncommon to lose up to 100 gallons a day from an invisible toilet leak.
- Use a water-efficient showerhead. They're inexpensive, easy to install, and can save you up to 750 gallons a month.
- Water plants only when necessary and adjust sprinklers so only your lawn is watered. Apply water only as fast as the soil can absorb it and during the cooler parts of the day to reduce evaporation.
- Don't run the hose while washing your car. Use a bucket of water and a quick hose rinse at the end or wash vehicles at a carwash that recycles its water. Saves 150 gallons each time.

Teach your kids about water conservation to ensure a future generation that uses water wisely.

Visit www.epa.gov/watersense for more information.

Remember, when you conserve water you also conserve energy!

