

**Marine Corps Installations East-Marine Corps Base Camp Lejeune
Wastewater Collection System**

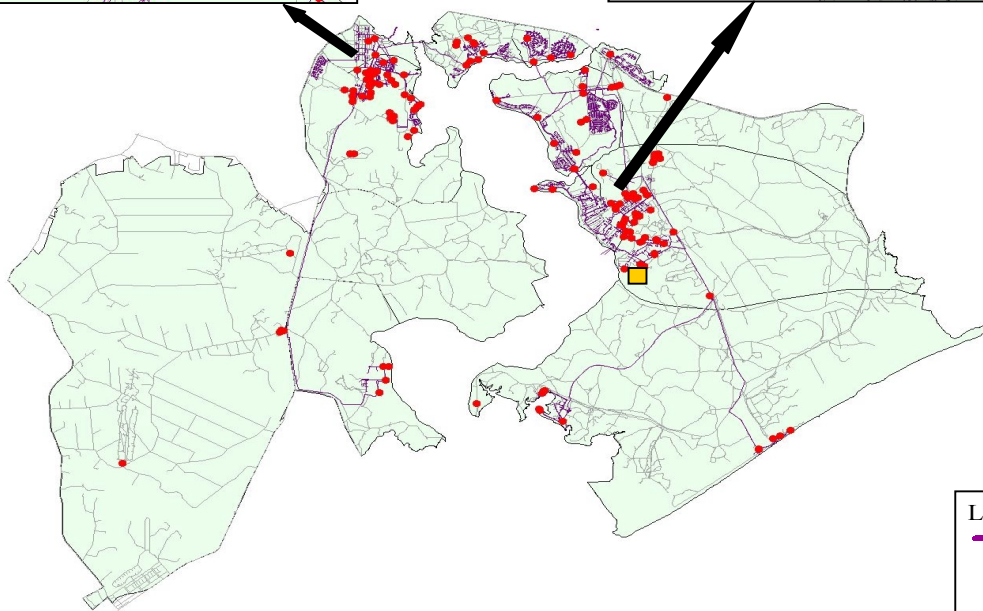

COLLECTION SYSTEM
131 Permitted Liftstations
(Approximate Values)
115 miles of gravity lines
89 miles of force main lines

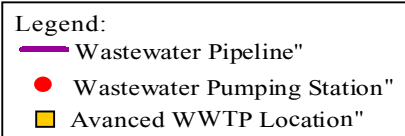

Marine Corps Installations East-Marine Corps Base Camp Lejeune

Advanced Wastewater Treatment Plant

Permit No. NC0063029

Wastewater Collection System

Permit No. WQCS00015

Annual Performance Report

July 2012 - June 2013



AWWTP Overall Performance

Overall operation of the T O O U V E T O O O C E T S O R A W W T P has { specifications

Summary of Violations

Wastewater Collection System - Public Reportable Spills

Wastewater Collection System - Public Reportable Spills

During the monitoring period of record there was one reportable sewage overflow (spills). A summary is listed below:

Reportable Sewage Overflows (spills)

Date	Estimated Volume (gal.)	Surface Water Reached	Location of Spill	Reason for Spill
7/16/2012	122,500	None	Parking lot area (corner of Burger King) at intersection of McHugh & Gonzalez Blvd's.	Break in pipe

Contacts

For additional copies of this report, more information, or questions concerning the T O O U V E T O O O C E T S O R A W W T P Wastewater Treatment System please contact the Director of Utilities at 910-451-5024. A newspaper article announcing the availability of this report was recently published in the Óase newspaper "The Globe" and the Marine Corps Air Station New River newspaper "Rotovue".

For questions concerning the North Carolina Wastewater Annual Performance Program contact the Point Source Branch, Expedited Permitting and Compliance Unit of the NCDENR, Division of Water Quality, Mr. Bob Sledge at 919-807-6398.

Definitions

mg/L (milligrams/Liter) are the units of concentration used to express environmental measurements. 1 mg/L is equivalent to 1 part per million (ppm). You can think of 1 ppm as 1 cent in \$10,000.

Influent - wastewater entering the treatment plant

Effluent - wastewater leaving the treatment plant

BOD (Biochemical Oxygen Demand) is a pollution indicator. It is a measurement of the dissolved oxygen needed by microorganisms to biologically degrade pollutants. The normal BOD test is conducted during a 5 day laboratory period and denoted BOD₅. Raw domestic sewage typically has a BOD₅ of about 200 mg/L whereas a typical BOD₅ of unpolluted surface water would be less than 5 mg/L. If discharged to the environment, water with an elevated BOD could deplete (use up) the dissolved oxygen in rivers and streams due to the biological degradation of the pollutants by naturally occurring microorganisms. This can cause fish kills and septic conditions.

TSS (Total Suspended Solids) is a pollution indicator. It is simply a measurement of undissolved solids. Similar to BOD, raw domestic sewage typically has a TSS of about 200 mg/L. If discharged to the environment, elevated levels of TSS can produce sludge deposits and cause septic conditions.

Ammonia Nitrogen (NH₃-N) represents the concentration of nitrogen bound in the ammonia form. Raw domestic sewage typically has an NH₃-N of about 15 to 20 mg/L. If discharged to the environment, elevated levels of NH₃-N can cause three problems. These include: (1) depletion of dissolved oxygen in rivers and streams because the biological degradation of ammonia is an oxygen consuming process, (2) impairment and death to fish and other aquatic organisms due to the direct toxicity of ammonia, and (3) increased growth of algae due to the nutrient effects of nitrogen.

Phosphorus is an essential nutrient for all biological growth. However, if discharged to the environment, elevated levels can cause excessive growth of algae and other aquatic plants. The subsequent decay of these plants can result in a depletion of dissolved oxygen.

Treatment Plant Diagram

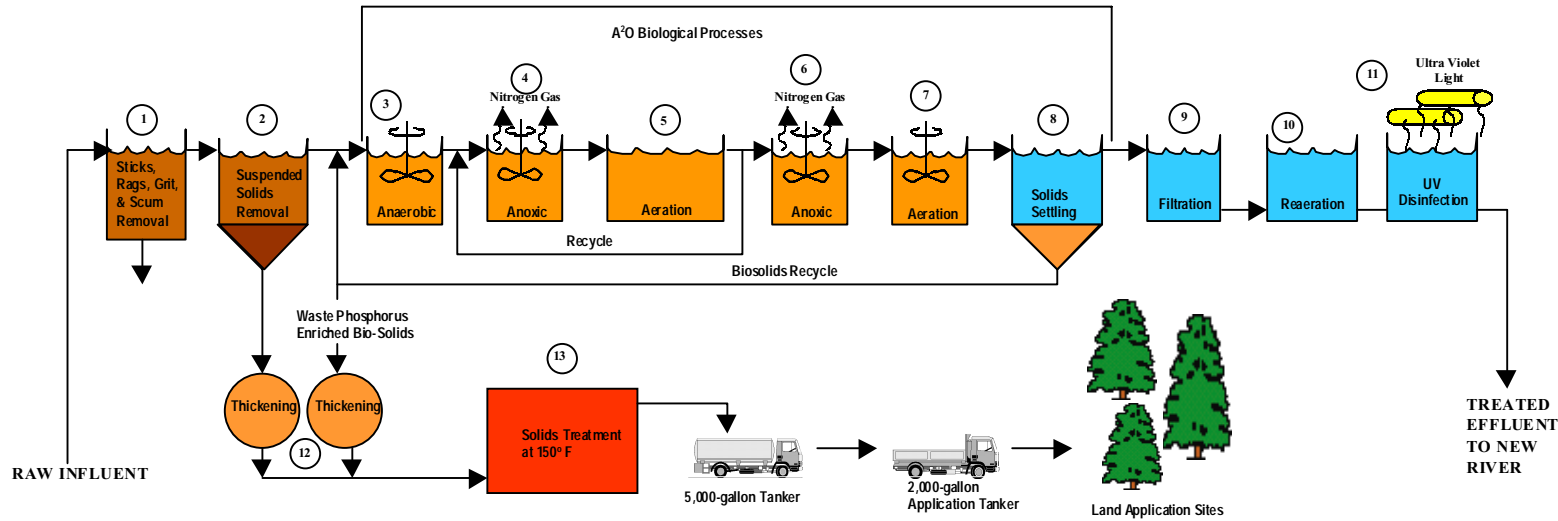

GENERALIZED WASTEWATER TREATMENT PLANT (WWTP) PROCESS DESCRIPTION

The Camp Lejeune Advanced Waste Water Treatment Plant (AWWTP) is an advanced biological process that consists of three different microbial environments. The combined environments are called the A²O process for Anaerobic, Anoxic and Oxidic. These three zones cultivate a special mix of beneficial microorganisms that absorb phosphorus and convert chemically bound nitrogen to harmless and inert nitrogen gas. Residual phosphorus not absorbed by the microorganisms is removed by chemicals added by the WWTP's operations staff. Other microorganisms (primarily in the oxidic zone) biologically degrade wastewater pollutants by using organic material as food and converting it to new microbes, carbon dioxide and water. All of the three A²O zones consist of mixed slurries of wastewater and microorganisms. After treatment, the water and microbes are separated by gravity settling in large tanks. The clean water is skimmed from the surface, filtered, disinfected with ultra-violet light and returned to the New River. The microbes are continuously collected from the bottom of the tanks and returned to the three A²O zones using recycle pumping systems. This recycling provides a continuous source of microbes to degrade incoming pollutants. As pollutants are removed, the microorganisms grow and multiply. This growth results in the production of excess microorganisms. These excess microbes are continuously removed (a process called wasting) to maintain a consistent and optimal balance between available microbes and the amount of food (pollutants) entering the WWTP. The

excess microorganisms (called residuals or biosolids) are treated at an elevated temperature (±150°F) to kill disease causing organisms, to reduce odors and for further treatment of biodegradable pollutants. The treated residuals are applied to agriculture and forest areas for their beneficial nutrients and soil conditioning characteristics. The flow of water into and out of the WWTP is a continuous operation — the WWTP operates 24 hours per day and 365 days per year.

Descriptions of the WWTP processes are summarized below:

1 — Preliminary Treatment is merely a screening process that removes large debris such as sticks, rags, grit and sand. The removal of these constituents protects downstream equipment.

2 — Primary Clarification consists of large tanks where suspended solids settle to the bottom. The settled solids are transferred to the solids treatment process. In general this process removes about 50% of the TSS entering the WWTP influent. The remaining fraction is either degraded (solubilized) in the biological processes or removed in the WWTP's secondary clarifier.

3 — The Anaerobic Zone is a mixed tank void of dissolved oxygen. The absence of all oxygen is conducive to the growth of special bacteria (*Acinetobacter*) that consume organic acids and release stored phosphorus in the anaerobic tank. However, these same organisms uptake high levels of phosphorus when they enter the aerobic (oxic) zone of the WWTP. Thus, the cycling of the microbes between the anaerobic and oxic environments is the mechanism responsible for enhanced phosphorus uptake. This cycling is accomplished by the normal flow of water and the recycle system that returns the microbes to the anaerobic zone after they have been oxygenated in the oxic zone of the WWTP. Phosphorus (a algae causing nutrient) is ultimately removed from the WWTP by wasting excess microbes after the oxygenated cycle and when stored phosphorus levels are greatest.

4 — The Anoxic Zone consists of mixed tanks that have essentially no dissolved oxygen. However, these tanks do contain oxygen that is chemically bound to nitrogen in a molecule called nitrate (NO₃-N). This nitrate nitrogen is a byproduct from the biological treatment of ammonia and is introduced to the anoxic zone through the recycle from the outlet of the aeration tank. In the absence of dissolved oxygen, bacteria in the anoxic zone break the chemical bond between the oxygen and nitrogen. The oxygen is used by the microbes to produce new bacteria, water and carbon dioxide. More importantly, the nitrogen (a nutrient responsible for the growth of excess algae) is removed from the water and released to the atmosphere as a harmless and inert gas.

5 — The Oxidic (Aerobic) Zone consists of mixed and oxygenated tanks. Oxygen is supplied from the atmosphere using mechanical agitators located on the surface of the tanks. In this process, aerobic (oxygen using) and other microorganisms perform the following:

Reduce BOD: This is the biological degradation of wastewater pollutants. Simply stated, microorganisms consume organic material for food and convert it to new microbes, carbon dioxide and water.

Nitrify Ammonia: This is the biochemical oxidation of ammonia nitrogen to the much more stable and benign form called nitrate nitrogen (NO₃-N). The benign NO₃-N can be biologically degraded to nitrogen gas when recycled to the anoxic zone of the WWTP.

Uptake of Phosphorus: The special bacteria (*Acinetobacter*) cultivated in the anaerobic zone absorb a significant amount of phosphorus in the aerobic tank. This absorbed phosphorus is ultimately removed from the wastewater when excess microorganisms are wasted from the WWTP.

6 — The Post Aerobic Anoxic Zone uses the same mechanisms as previously described to convert nitrate to nitrogen gas. This particular zone is simply another location to cultivate special microbes and provide an additional opportunity for these organisms to convert nitrate to inert nitrogen gas.

7 — The Second Stage Aeration Zone consists of small aerated tanks. This particular zone is simply used to return dissolved oxygen to the water following the anoxic (oxygen free) process.

8 — Secondary Clarification consists of large tanks where the suspended biosolids (microorganisms) are separated from the water; the biosolids simply settle to the bottom of the tank. As a general rule of thumb, approximately 97 to 98% of the biosolids entering the secondary clarifier are recycled back to the anaerobic zone so they can treat incoming waste products. About 2 to 3% of these "phosphorus enriched biosolids" are due to the growth of excess microbes and are wasted to the solids treatment process.

9 — Filtration is a polishing process that removes the trace levels of suspended solids that do not settle in the secondary clarifier. This process employs a layer of sand that removes the solids by straining and adsorbing suspended material.

10 — The Reaeration Process is a small aerated tank used to increase the level of dissolved oxygen in the treated water just before it is discharged. This helps maintain a higher oxygen content in the New River in the vicinity of the WWTP's discharge line.

11 — Disinfection is the final process in the WWTP. It is used to kill disease causing microorganisms. It is important to note that no chemicals are used in disinfection process at this WWTP — biological kills are accomplished using environmentally benign ultraviolet (UV) light.

12 — Solids Thickening is used to remove some of the water from the slurry of waste biosolids. Thickening is used to reduce the volume of waste solids and increase the capacity of the WWTP's residuals processing tanks. As a general rule, thickening reduces the volume by about 65 to 75%.

13 — Solids Treatment is used to kill disease causing organisms, reduce odors and for further treatment of the biodegradable pollutants in the biosolids. The process consists of mixed and aerated tanks operated at about ±150°F. The heat is generated internally from the biological decomposition of the biosolids by special bacteria that flourish in this type of environment. This process is similar to composting.

AWWTP Permit Limits and Performance Data

Parameter	Permit Limits on AWWTP Effluent	
	Monthly Average Limitation (mg/L)	
	April 1 to October 31	November 1 to March 31
BOD ₅	5	10
TSS	30	30
NH ₃ -N	2	4
Phosphorus	0.5	1

Parameter	Influent (mg/L)	Effluent (mg/L)	Removed

Biosolids Production During the 12 Month Period
